



Operating and Assembly Instructions for couplings: **Ex-HKS 5, Ex-HKDS 5** with Ex-protection approval

Read the Operating and Assembly Instructions prior to
assembly, starting installation and handling!
Keep for future reference!

 Download
PDF



Manufacturer / publisher

Johannes Hubner
Fabrik elektrischer Maschinen GmbH
Siemensstraße 7
35394 Giessen
Germany
Phone: +49 641 7969 0
Fax: +49 641 73645
E-Mail: info@huebner-giessen.com
www.huebner-giessen.com

The manual has been drawn up with the utmost care and attention. Nevertheless, we cannot exclude the possibility of errors in form and content. It is strictly forbidden to reproduce this publication or parts of this publication in any form or by any means without the prior written permission of Johannes Hubner Fabrik elektrischer Maschinen GmbH.
Subject to errors and changes due to technical improvements.

Copyright © Johannes Hubner Fabrik elektrischer Maschinen GmbH
All rights reserved.

Table of contents

1	General	4
1.1	Information about the operating and assembly instructions	4
1.2	Scope of delivery	4
1.3	Explanation of symbols.....	5
1.4	Disclaimer	6
1.5	Copyright	6
1.6	Guarantee terms.....	6
1.7	Customer service.....	6
2	Safety.....	7
2.1	Responsibility of the owner.....	7
2.2	Personnel.....	7
2.3	Personal protective equipment.....	7
2.4	Special dangers.....	8
2.4.1	Rotating shafts.....	8
2.4.2	Exceeding the maximum speed	8
2.4.3	Heat	8
2.4.4	Electrical current.....	8
2.4.5	Lightning strike.....	8
2.4.6	Rust deposit.....	8
3	Mechanical Data.....	9
3.1	Type plates	9
3.1	Intended use	10
3.2	Non intended use	11
4	Installation and Commissioning	12
4.1	Safety note.....	12
4.2	Technical Notes	12
4.3	Required Tools	12
4.4	Preparation of the installation	12
4.5	Mounting	13
5	Dismantling	13
6	Inspections.....	14
6.1	Safety inspections	14
6.2	Maintenance Information	14
6.3	Inspection schedule.....	14
7	Disposal.....	14
7.1	Disposal procedure.....	14
8	Dimension drawings.....	15

1 General

1.1 Information about the operating and assembly instructions



These Operating and Assembly Instructions provide important instructions for working with the coupling. They must be carefully read prior to starting all tasks, and the instructions contained herein must be followed.

In addition, applicable local regulations for the prevention of industrial accidents and general safety regulations must be complied with.

These Operating and Assembly Instructions have been drawn up with the utmost care and attention. Nevertheless, we cannot exclude the possibility of errors in form and content. It is strictly forbidden to reproduce this publication or parts of this publication in any form or by any means without the prior written permission of

Johannes Hubner Fabrik elektrischer Maschinen GmbH.

Subject to errors and changes due to technical improvements.

These Operating and Assembly Instructions have been written to enable the owner to safely and properly transport, assemble, commission and maintain the explosion-protected coupling. We reserve all rights to make technical changes to the coupling described in the instructions below. Drawings and images are simplified representations. Due to improvements and modifications it is possible that they differ in some minor details from the device supplied. Technical data and dimensions are not binding. They are provided for information purposes only and are not guaranteed characteristics. The customer will be informed immediately if modifications affect couplings already supplied.

Due to the wide variety of application conditions, these Operating and Assembly Instructions can only take into consideration general application conditions to maintain clarity and oversight. In special cases, such as in unusual ambient conditions or when particularly stringent safety regulations apply certain operating characteristics must be agreed with the manufacturer or the distributor.



Caution!

Read installation, operating and maintenance documents before transport, installation, commissioning, maintenance and repair and observe notes!

Retain the safety instructions and the Operating and Assembly Instructions for future reference!



Commissioning procedures **MUST ONLY** be carried out by personnel who are able to provide verification of special training to work on Ex certified machinery.

1.2 Scope of delivery

- coupling
- Operating and Assembly instructions
- CE-Explanation

1.3 Explanation of symbols

Warnings are indicated by symbols in these operating and assembly instructions. The warnings are introduced by signal words that express the scope of the hazard.

The warnings must be strictly heeded; you must act prudently to prevent accidents, personal injury, and property damage.

**WARNING!**

Indicates a possibly dangerous situation that can result in death or serious injury if it is not avoided.

**CAUTION!**

Indicates a possibly dangerous situation that can result in minor injury if it is not avoided.

**CAUTION!**

Indicates a possibly dangerous situation that can result in material damage if it is not avoided.

**NOTES!**

Indicates useful tips and recommendations as well as information for efficient and trouble-free operation.

**NOTES!**

The use of a hammer or similar tool during mounting is not permitted!

**WARNING!**

If components are missing, do not add these components by own components. Otherwise the declaration of conformity loses its validity.

1.4 Disclaimer

All information and instructions in these (operating and assembly instructions) have been provided under due consideration of applicable guidelines, as well as our many years of experience.

The manufacturer assumes no liability for damages due to:

- Failure to follow the instructions in the operating and assembly instructions
- Non-intended use
- Deployment of untrained personnel
- Conversions of the couplings

In all other aspects the obligations agreed in the delivery contract as well as the delivery conditions of the manufacturer apply.

1.5 Copyright



NOTES!

Content information, text, drawings, graphics, and other representations are protected by copyright and are subject to commercial property rights.

It is strictly forbidden to make copies of any kind or by any means for any purpose other than in conjunction with using the coupling without the prior written agreement of the manufacturer. Any copyright infringements will be prosecuted.

1.6 Guarantee terms

The guarantee terms are provided in the manufacturer's terms and conditions.

1.7 Customer service

For technical information personnel is available that can be contacted by telephone, fax or email. See manufacturer's address on page 2.

2 Safety



DANGER!

This section provides an overview of all the important safety aspects that ensure protection of personnel, as well as safe and trouble-free coupling operation. If these safety instructions are not complied with significant hazard can occur.

2.1 Responsibility of the owner

The coupling complies with the EU directive 2014/34/EU for potentially explosive atmospheres and with the IECEx-Scheme.

The coupling is used in commercial applications. Consequently the owner of the coupling is subject to the legal occupational safety obligations and subject to the safety, accident prevention and environmental protection regulations that are applicable for the couplings area of implementation. For all subsequently made works by the purchaser on components with fault exclusion the purchaser shall be solely responsible. Warranty claims arising from inadequately performed rework will not be taken over by Johannes Hubner Fabrik elektrischer Maschinen GmbH. Any mechanical rework on components with fault exclusion needs the necessary examination and the written approval by Johannes Hubner Fabrik elektrischer Maschinen GmbH.

It is not permissible to make any alteration to equipment that is used in potentially explosive environments. Repairs may only be carried out by authorized authorities provided by the manufacturer. **Contravention invalidates the EX approval.**



The coupling must be operated in accordance with the stipulations of the Operating and Assembly Instructions. The relevant laws, regulations and standard for the planned application must be observed.

2.2 Personnel

Installation and commissioning as well as disassembly routines must be carried out by skilled technical staff only.

2.3 Personal protective equipment

Wear personal protective equipment such as safety shoes and safety clothing to minimise risks to health and safety when carrying out work such as mounting, disassembling or commissioning. Adhere to all applicable statutory regulations as well as the rules and standards determined by the owner.

2.4 Special dangers

Residual risks that have been determined based on a risk assessment are cited below.

2.4.1 Rotating shafts



WARNING!

Danger of injury due to rotating shafts and hot surfaces!

Touching rotating shafts can cause serious injuries.

Therefore:

Do not reach into moving parts/shafts or handle moving parts/shafts during operation. Close to protect from injury all access openings in flanges with the corresponding plug screw, and provided you exposed rotating components with protective covers.

Do not open covers during operation. Prior to opening the covers ensure that all parts have come to a standstill.

2.4.2 Exceeding the maximum speed



WARNING!

If the mechanical data according to the table become exceeded, the declaration of conformity loses its validity.

2.4.3 Heat



WARNING!

With additional heat energy input (e.g. from the sun or machines), the ambient temperature and radiated heat together may cause a maximum of 80 ° C heating of the coupling.

2.4.4 Electrical current



WARNING!

No electrical currents may be conducted via the coupling.

2.4.5 Lightning strike



WARNING!

The user must take precautions in the integration so that a suitable grounding occurs in the event of lightning strikes.

2.4.6 Rust deposit



WARNING!

Rust deposits must be avoided. This must be checked by regular optical checks (see chapter 6.3).

3 Mechanical Data

Specification	Value	Unit
Shock resistance	short time 100 continuous load 10	g
Vibration resistance	Short time 20 continuous load 3	g
Torque	3	Nm
Ambient temperature	-50 ... +70 (Ex-HKS and Ex-HKDS)	°C
Max. speed	6000	rpm
Mounting precision	<u>Ex-HKS 5</u> axial misalignment: ± 1 mm angle : 0,5°	
	<u>Ex-HKDS 5</u> axial misalignment: ± 1,5 mm radial misalignment: ± 0,5mm	

NOTE!



If the permissible mounting accuracies becomes exceeded, the load on the coupling increases. The fatigue strength can then no longer be ensured.

The breakage of an overloaded spring should be monitored by the signal matching of the motor and transmitter signals. If these values deviate from one another, a coupling defect must be assumed by overloading and the entire system must be transferred to a safe state. The coupling must then be checked for damage (see chapter 6.3 inspection schedule “).

3.1 Type plates

Type plates example:



The type plates are located on the coupling hub and contain the following information:

- Manufacturer
- Type
- IECEx Certification Authority
- Explosion protection marking for ATEX and IECEx

The serial number is engraved on the coupling hub.

Date of manufacture: ____ . ____ . ____ ID number _____

3.1 Intended use

The coupling is intended exclusively for use with a rotary encoder.

The function will only be reached when the coupling is carried out according to these instructions. Only use components specified by Johannes Hubner Fabrik elektrischer Maschinen GmbH.

The device is in accordance with equipment category 2G (EPL Gb) and equipment category 2D (EPL Db) designed and constructed.

- Ex-labeling: Ex h IIC T6 Gb X
Ex h IIIC T85°C Db X
- Conforms to standard: IEC 60079-0 Ed. 7
DIN EN 60079-0 06/2014
IEC 80079-37 Ed.1.0
DIN EN ISO 80079-37 12/2016
IEC 80079-36 Ed.1.0
DIN EN ISO 80079-36 12/2016
- type of ignition protection: c
- Temperature class: T6, T85°C
- Explosive group: IIC, IIIC

The operation in other explosive atmospheres is not permissible.

Type of coupling	Device category	Equipment Protection Level	Temperature class	Ambient temperature
Ex HKS und Ex HKDS	2G	Gb	T6	-50°C ... 70°C
	2D	Db	T85°C	-50°C ... 70°C

Possible Ignition Sources

Possible Ignition Sources	Equipment Related?	Reason
Hot surfaces	Yes	environmental temperature and heating from radiation
Mechanical sparks	Yes	damage of the coupling springs
Flames, hot gases	No	Not present
Electrical sparks	No	Not present
Stray electric currents and cathodic corrosion protection	No	Not present
Static electricity	Yes	insulating components
Lightning	No	Actions must be taken by the user
Electromagnetic waves	No	Not present
Ionising radiation	No	Not present
High frequency radiation	No	Not present
Ultrasonic	No	Not present
Adiabatic compression	No	Not present
Chemical reaction	Yes	combination of aluminium and stainless steel



ATTENTION!

For safety reasons, 2 spring plates are installed in parallel. If a spring plate is damaged, the coupling may not continue to be operated.

3.2 Non intended use

All limit values stated in the instructions must be observed. Exceeding is not intended.

4 Installation and Commissioning

4.1 Safety note



Note!

Observe the safety instructions contained in chapter 2 when installing and during other work on the coupling!

Personnel

Installation and commissioning must be carried out by skilled technical staff only.

4.2 Technical Notes



Danger!

Do not use a hammer or similar tool when mounting the coupling.

Ambient temperature

The max. permissible ambient temperature must be observed. Otherwise, the declaration of conformity loses its validity.

4.3 Required Tools

- Allen key 2 mm

4.4 Preparation of the installation

1. Clean the shafts and check for damage. Repair any damage.
2. Check the existing shaft offset (axial, radial and angle) and adjust with the permissible values.

4.5 Mounting

1. Lightly grease the (motor) shaft
2. Fit coupling onto (motor) shaft. You must be able to mount the coupling without force.
3. Secure the coupling hub on the (motor) shaft with a grub screw
4. Lightly grease the encoder shaft.
5. Mount the encoder.
6. Ensure that the coupling is not prestressed as far as possible.
7. Secure the coupling hub on the encoder shaft with a grub screw. All set screws must be secured with Loctite® thread locker.

**WARNING!**

The spring lamellas must not be overloaded during assembly. For this reason, it is forbidden to act on the hubs by means of hammer or similar tools. Installation must be easy.

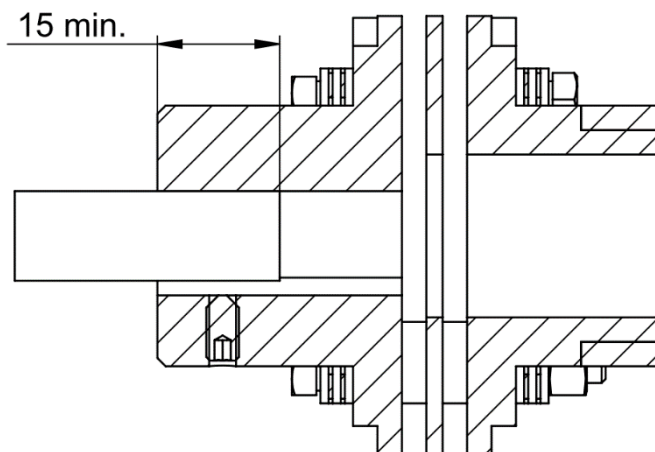

The hub and shaft overlap must be at least 15 mm. The shafts must be included in the equipotential bonding. See the following sketch.

**WARNING!**

It must be ensured that there is no contact between the coupling and the surrounding components during operation.

5 Dismantling

To dismantle follow the installation in reverse order.

6 Inspections

6.1 Safety inspections



NOTE/PERSONNEL

Skilled technical staff only are permitted to inspect the coupling and the installation. Observe the safety instructions contained in **Chapter 2** when inspecting or working on the coupling!

6.2 Maintenance Information

The coupling is maintenance free. However, to guarantee optimum fault-free operations we recommend that you carry out the following inspections.

6.3 Inspection schedule

Interval	Inspection
Yearly	Check spring lamellas for damage
	Visual check for visible changes
	Check clamping screws for tightness
	There must be no rust deposits



WARNING!

A repair may only be carried out by Johannes Hubner Fabrik elektrischer Maschinen GmbH.

7 Disposal

7.1 Disposal procedure

The manufacturer is not obliged to take back the adapter flange.

For information on environmentally sound disposal please contact your local authority or a special disposal company.

Ex-HKDS 522

Ex-HKDS 532

Ex-HKDS 533

2. Nabe um 90° versetzt dargestellt!

Lage der Gewindestifte bei $d \geq 20$:
Gegenüber der Passfedernut
Position of set screws if $d \geq 20$:
Opposite of feather keyway!

Gewindestift
set screw
ISO 4027 - M4

zulässige Nachgiebigkeit / permissible resilience:
axial / axial $\pm 1,5$ mm
radial / radial 0,5 mm

Änderungen vorbehalten
modifications reserved

Verwendung:		Messeib:	
Zust.	Änderung	Name	Form:
		Datum <td>Name</td>	Name
		13.03.2018	D. Häuser-B.
		13.03.2018	S. Malberger
		13.03.2018	S. Malberger
		elektronisch freigeben / V6	
		JOHANNES HÜBNER GIESSEN	
		Datum	Name
			orig. format: A3
		Ers. d:	

Maltzeichnung / dimension drawing	
Verdrehsteife Doppelgelenk-Kupplung Torsion-resistant double-joint coupling	
Ex-HKDS 5...	
Blatt	1
Blatt	1
HM 18 M 112395	

**Andere Nabenbohrungen auf Anfrage
Other hub bores on request**

d1 G7 / d2 G7	Abmaße/ tolerance in µm	t ^{+0,1}	u JS9	Abmaße/ tolerance in µm
8	+5	+20	2	± 12,5
10	+5	+20	3	± 12,5
11	+6	+24	4	± 15
12	+6	+24	4	± 15
13	+6	+24	5	± 15
14	+6	+24	5	± 15
15	+6	+24	5	± 15
16	+6	+24	5	± 15
18	+6	+24	6	± 15
19	+7	+28	6	± 15
20	+7	+28	6	± 15
22	+7	+28	6	± 15

Ex-HKDS 568

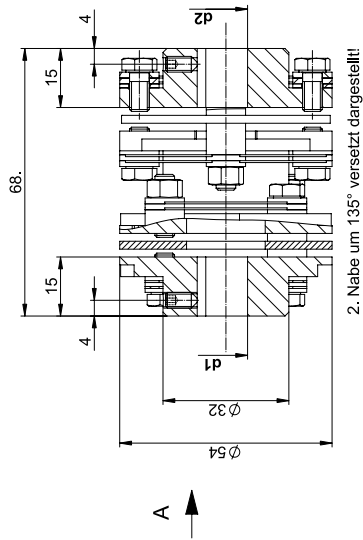

2. Nabe um 135° versetzt dargestellt!

A

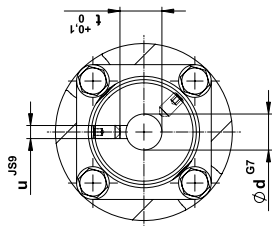

Lage der Gewindestifte bei $d \geq 20$:
Gegenüber der Passfedernut!
Position of set screws if $d \geq 20$:
Opposite of leather keyway!

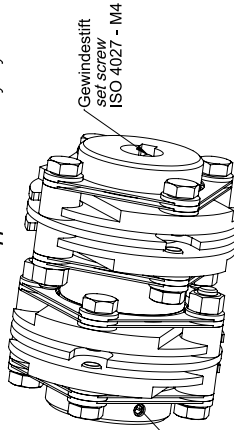

Gewindestift
set screw
ISO 4027 - M4

zulässige Nachgiebigkeit / permissible resilience:
axial / axial $\pm 1,5$ mm
radial / radial 0,5 mm

Änderungen vorbehalten
modifications reserved

Andere Nebenbohrungen auf Anfrage Other hub bores on request

d1 G7 / d2 G7	Abmaße/ tolerance in μm	t $+0,1$	u JS9	Abmaße/ tolerance in μm	
10	+5	+20	11,4	3	$\pm 12,5$
11	+6	+24	12,8	4	± 15
12	+6	+24	13,8	4	± 15
14	+6	+24	16,3	5	± 15
15	+6	+24	17,3	5	± 15
16	+6	+24	18,3	5	± 15
18	+6	+24	20,8	6	± 15
19	+7	+28	21,8	6	± 15
20	+7	+28	22,8	6	± 15

Verwendung:		Mittelab:	
Besch.	Datum	Name	
11.04.2018	11.04.2018	D. Häuser-B.	
Gepr.	11.04.2018	M. Eilers	
Freige.	11.04.2018	M. Eilers	
elektronisch freigeben / V10			
HUBNER			
JOHANNES SIEBEN			
Zust.	Änderung	Datum	Name / orig. format: A3
Maltzeichnung / dimension drawing			Blatt
Verdrehsteife Doppelgelenk-Kupplung			1
Torsion-resistent double-joint coupling			1 Bl.
Ex-HKDS 568			
Stück-Nr./Z-Nr.			
HM 18 M 112398			
Ers. f.			

